



**STORAGE, ERECTION, OPERATION
AND MAINTENANCE MANUAL FOR
CENTRIFUGAL FANS**

MODEL - KXE

CUSTOMER :



CONTENTS

1	SAFETY	5
1.1	General	6
1.2	Description of symbols and pictograms	6
1.3	Start - up	6
1.4	Servicing	7
1.5	Cleaning	7
1.6	Electrical	7
1.7	Description of labels and plates	8
2	APPLICATION	9
2.1	Design conditions	9
2.2	Warranty	9
3	DESCRIPTION	9
3.1	Design	9
3.2	Options	10
4	ASSEMBLY AND INSTALLATION	10
4.1	Scope of supply	10
4.2	Transport	10
4.3	Storage	11
4.3.1	Stand - by operation	11
4.4	Site Installation	11
4.5	Pipes connected to the fan	11
4.6	Electrical connection	12
4.7	Inspection	12
4.7.1	Mechanical testing	12
4.7.2	Electrical testing	13
5	START-UP	13
5.1	Putting the fan into operation	13
5.2	Putting the fan out of operation	13
5.3	Transient behaviour	14
5.3.1	General	14
5.3.2	Direct starting	14
5.3.3	Star delta starting	14
6.	CARE AND MAINTENANCE	15
6.1	Lubrication	15
6.1.1	Drive motor	15
6.1.2	Shaft seal	15
6.1.3	Shaft bearings	15
6.1.4	Operating Technique	15
6.2	Coupling	20
6.2.1	Service	20
6.2.2	Alignment	20
6.3	Troubleshooting	21
6.3.1	Troubleshooting shaft defects	22
6.3.2	Troubleshooting coupling defects	23
6.4	Queries/Spare Parts order	23



SAFETY PRECAUTIONS

The operation and maintenance of machinery of any kind require the person to be cautious and aware of the damages that exist. In order to avoid injuries to personal and damage to machinery, the following precautions are necessary.

1. Never apply power to the fan motor for any reason until the fan has been completely installed in its system, and the system inspected to make sure that no debris has been left in the fan and ducts, and it is known that the inspection doors at the inlet and outlet of the air passages are closed. The usual procedure is to remove the fuses from the disconnect switch and open its safety isolation switch until the installation is complete and fully inspected.
2. Start the fan momentarily and disconnect it. Observe rotation of the wheel and make sure that the drive rotation is correct. Do not allow the fan to run backwards, except only momentarily.
3. Do not open or access the inspection doors while the fan is running.
4. Always open the disconnect switch and lock it in the open position with a padlock before doing any service or maintenance work on the fan.
5. After service of any kind, make sure that all adjustments have been properly made and tightened, inspection doors closed, there is no debris in the air passages and all tools have been removed before unlocking the disconnect switch to place the fan in operation.
6. Make a periodic inspection of the fan impeller, bearings and coupling to be sure that corrosion has not set in to weaken them. Where there are signs of corrosion there is a possible danger of mechanical failure. Corroded parts should be replaced.
7. Always use caution in every maintenance or operational procedure.

1.1 GENERAL

The fan meets the technical safety standards applicable at the time of delivery. The rules and regulations for the prevention of accidents applicable at the time of delivery were taken in to account in the fan design.

It is not allowed to modify the original condition of the fan without the approval of Reitz. The warranty expires when parts other than original Reitz spare parts and/or purchased parts not corresponding to the original parts are used.

The operating manual and any required supplementary manuals must be available to the operator.

It must be ensured that fans which are installed at high levels can only be reached via means of access especially installed for this purpose.

All devices and installations provided to prevent noxious substances from escaping must be checked before the fan is put into operation.



Do not bypass, loosen or remove guards and protective devices.

Do not open inspection ports and/or other openings when the fan is in operation.

1.2 Description of symbols and pictograms



This symbol draws your attention to dangerous situations. The operation concerned may endanger persons and cause injuries.



This symbol is used to indicate that the work must be carried out by a trained and qualified electrician.



This symbol is followed by supplementary information.

1.3 Start-up

The fan may only be put into operation (also for testing) when the inlet and outlet ports are provided with suitable guards/plate shutters or when pipes are connected to them.

Before the fan is started the housing and all pipes connected to it must be checked. They must be dry and free of screws, bolts ,tools and other foreign substances.



Disregarding the above instructions may cause accidents and destroy the fan. Observe the safety regulations for electrical machines and equipment.

(→ Electrical safety)

1.4 Servicing

The fan may only be serviced when the electrical system is dead, i.e.;

- turn off the electrical machines and ensure that they cannot be switched on again,
- wait until the rotor has come to a standstill,
- remove the motor fuse,
- disconnect the power supply cable for the motor.

After servicing, guards and protective devices must be installed and all pipes must be connected again. All bolts and nuts must be tightened. Close all inspection openings and tighten the bolts and nuts.

The fan can then be put into operation again.

1.5 Cleaning

Do not clean moving parts when the fan is in operation.

Before cleaning, the fan must be put out of operation. Ensure that the fan cannot be switched on again accidentally.

Only use suitable detergents and cleaning materials.



If material is sticking to the impeller or the impeller is worn out, the fan may be seriously damaged by unbalance. It is therefore recommended to clean and check the fan for unusual vibrations at regular intervals.

1.6 Electrical safety

The user has to ensure that the fan is only connected and serviced by a qualified electrician in accordance with the rules and regulations applying to electrical equipment.

The user must also ensure that the fan is operated in accordance with electro-technical rules and regulations.

Do not touch/work on live parts.

- Interrupt the power supply to the fan and use mechanical means to ensure that power supply cannot be switched on again.
- Use a voltage tester to check that the circuit is dead.
Connect and short the work site to earth.
- Only use the fuses indicated in the electric circuit diagram.
- Check the condition of the visible cables before the fan is started.
- Replace damaged cables.

Damaged and/or defective electrical equipment must be repaired or replaced immediately. If the damaged equipment represents a risk, the fan may not be put into operation before the defect is repaired.

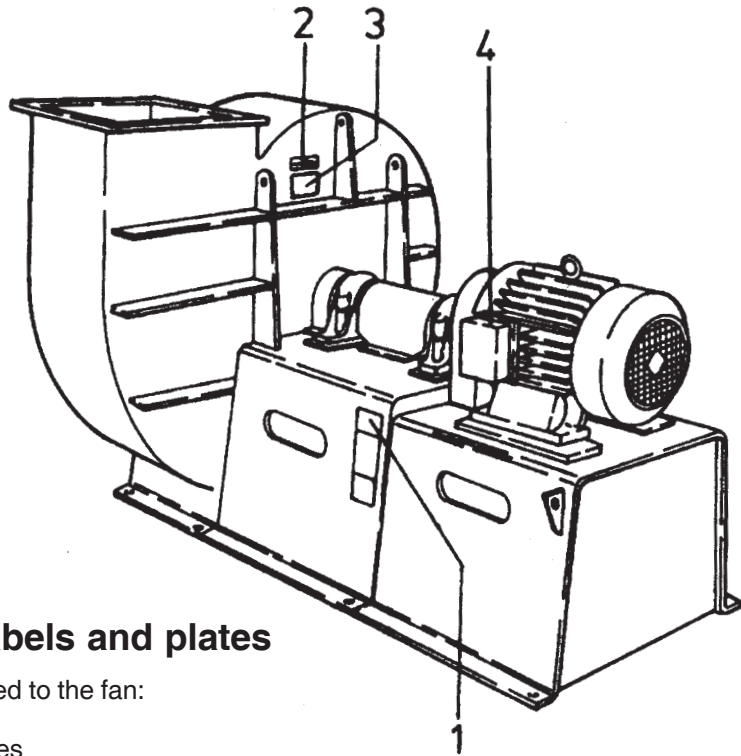

1.7 Description of labels and plates

The following plates are attached to the fan:

1. Nameplate
The nameplate indicates

REITZ INDIA LTD.		CREITZ I N D I A	
HYDERABAD - INDIA			
CUSTOMER :	[REDACTED]		
FAN MODEL # :	[REDACTED]		
JOB ORDER # :	[REDACTED]	TAG# :	[REDACTED]
YEAR OF MFR. :	[REDACTED]	CONSULTANT# :	[REDACTED]
DENSITY :	[REDACTED] KG/m ³	MEDIUM :	[REDACTED]
FLOW RATE :	[REDACTED] M ³ /HR	ST. PRES. :	[REDACTED] MMWG
TEMPERATURE :	[REDACTED] °C	SPEED :	[REDACTED] RPM

2. Arrow showing the sense of rotation of the impeller.
3. Company Logo
4. Motor nameplate



2. APPLICATION

2.1 Design conditions

The fan is designed, tested and supplied in accordance with the instructions given in the Purchase order.

The basic instructions indicated in the order have been entered and shown on the name plate. It is not permitted to change the conditions under which the fan is to be used.

2.2 Warranty

The warranted data refer to the single values and testing conditions in accordance with the applicable standards and/ or codes of practice. The special characteristics and local conditions of the plant in which the fan is to be incorporated must be taken into account by the plant designer and/ or planning engineer in his order.

He has to base his order on the actual operating conditions.

3. DESCRIPTION

3.1 Design

The KXE model fan is a welded single-stage centrifugal fan. It is driven by a motor via a shaft which is coupled to the fan shaft. The fan shaft is separately supported by two anti-friction bearings. The coupling is extremely flexible (in longitudinal and transverse directions). The torque is transmitted by a flexible intermediate ring which can be replaced.

The fan has connections for flat flanges as per Reitz standards.

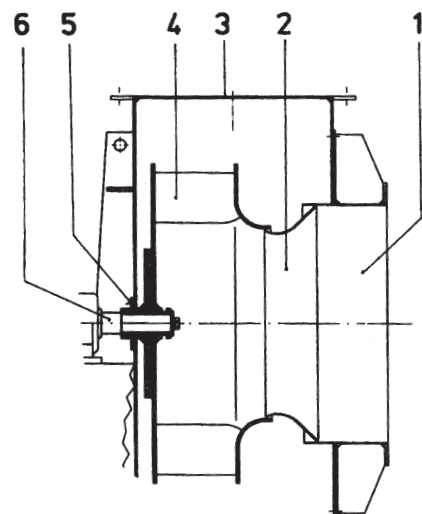
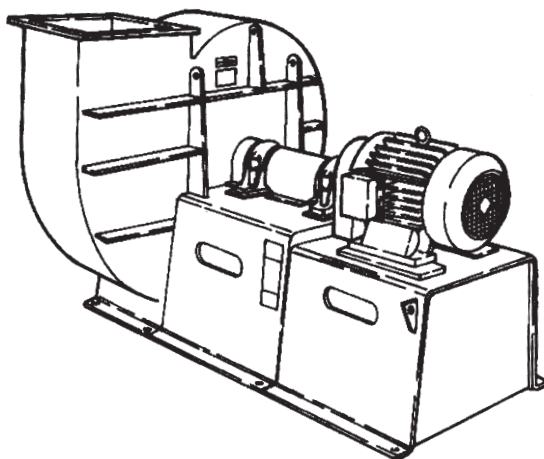

- | | |
|------------------|----------------|
| 1 - Inlet socket | 4 - Impeller |
| 2 - Inlet cone | 5 - Shaft seal |
| 3 - Casing | 6 - Shaft |

 For special designs, please note the information provided on the General arrangement drawing of the fan.

In standard designs (i.e. the temperature of the medium does not exceed +80 c) the ports for the shaft are sealed with a felt strip . For temperatures above 80 c the parts are sealed as per Reitz standards.

 This seal is not completely tight! For special shaft seals please refer to the information provided in the annexure.

3.2 Options

Accessories are available to adapt the fan to certain specific plant characteristics.
For additional information see (→ Annexure)

4. ASSEMBLY AND INSTALLATION

4.1 Scope of supply

When delivered the fan and accessories must be checked for damage caused by damaged packing

Immediately report any transport damage to the forwarding agent, insurance company and supplier. Any claims on transportation damages is not entertained by the fan supplier.

Check that everything indicated on the delivery note has been delivered.
In all other respects please refer to our terms and conditions for sale and delivery.

4.2 Transport

Only transport the fan with transport facilities which are appropriate for the conditions on the site where the fan is to be installed.

 Observe the applicable rules and regulations for the prevention of accidents.

For lifting and transporting the fan, only ropes and/ or fork lift trucks with a sufficient lifting capacity may be used.

Only attach ropes to the fastening plates (1) especially provided for lifting the fan.

 Do not sling lifting ropes to the inlet/outlet parts, fan shaft or motor. Do not use the eyelet on the motor for transporting the fan.

Warranty claims or claims for compensation for any damage caused by the use of unsuitable means of transport or caused by improper handling will not be accepted.

4.3. Storage

If the fan is not installed and / or put into operation immediately, it must be stored in a dry place which is free of vibrations.

In case of long-term storage please note the storage and preservation instructions for motors and fans.

4.3.1 Stand-by operation

In case of prolonged standstill periods, please refer to the relevant instructions for the storage of motors and fans!

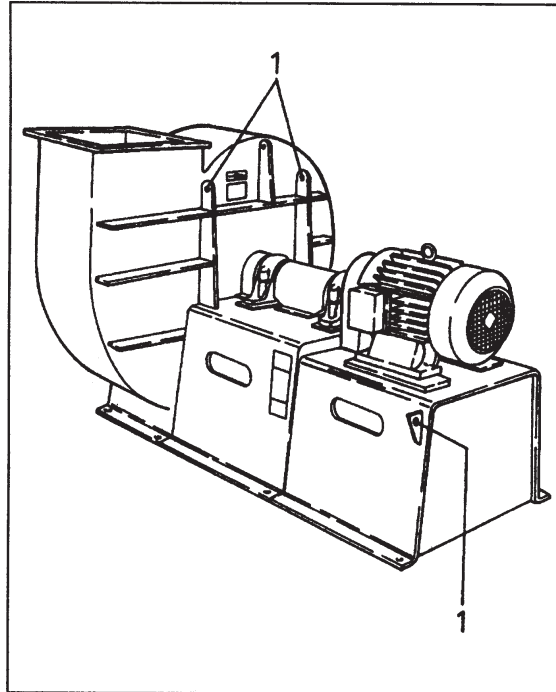

4.4 Installation site

The installation site must be level and should have a sufficient load bearing capacity. There must be enough space for assembly and maintenance work. The impeller must be easily accessible.

4.5 Pipes connected to the fan

 When attaching the pipes to the fan care must be taken that the fan is not distorted.

- Remove the transport shutters from the connection parts.
- Install the pipes in a manner ensuring that they are exactly aligned with the inlet and outlet parts of the fan.
- Connect the pipes with flexible connection (compensators) to the inlet and outlet parts of the fan (optional)

4.6 Electrical connection



The fan may only be connected up to the electrical system by a qualified electrician. The drive motors are usually installed by the purchaser. The works warranty does not apply if the customer installs the motor.

(→ Chap. Electrical safety)

The operating instructions of the motor manufacturers must be observed.

The motor is connected in accordance with the circuit diagram inside the terminal box (1). The customer has to check that his power network and the switch gear and monitoring devices are sufficiently dimensioned to cope with the transient behaviour and current peaks. It must be ensured that the supply of cooling air to the electric motor is not hindered.

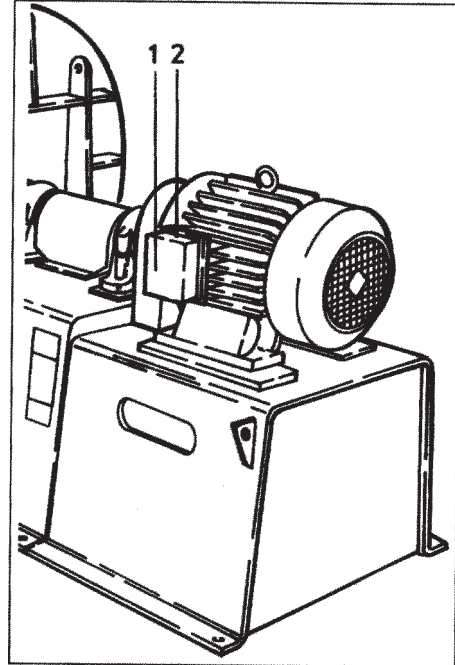

- The power supply cable for fan must be installed in accordance with the applicable legal stipulations.
- Compare the local mains voltage with the voltage indicated on the rating plate of the fan.
- Connect the fan as shown on the circuit diagram inside the terminal box (1)
- Earth the fan in accordance with the regulations issued by the local power supply company.
- Check the speed and sense of rotation.
- Check the transient behaviour and starting time.
- Provide for a motor protection system.

4.7 Inspection

4.7.1 Mechanical testing

Check the fan after it has been assembled and installed.

- Check the attachment of the fan to the foundation
- Check if the impeller rotates freely (turn it with the hand).
- Remove any foreign objects from the fan housing.
- Check all screw couplings and bolted connections.
- Check all pipe connections.

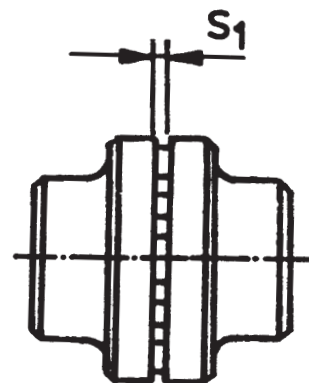

- Check the grease fill of the bearings and check that bearings are correctly aligned. Correct if necessary.
- Check alignment and dimension S1 of the coupling (i.e Coupling gap). Correct if necessary.
- Check the grease fill-up in the coupling (in case of resilient coupling). Fill it if necessary.
(→ Maintenance 6.2.2)

4.7.2. Electrical testing



The electrical system of the fan may only be tested by a qualified electrician.

- Check the operating voltage.
- Check the earthing.
- Check the size of the fuses.

If the fan is not put into operation immediately after it has been assembled and installed, it must be secured against unauthorized use and covered with a tarpaulin.

5. START-UP

5.1 Putting the fan into operation



The fan may only be put into operation by qualified and skilled staff. Before the fan is put into operation the staff must check that the fan is in good working order. The rules and regulations for putting electrical machines into operation must be observed.

- Check the safety systems.
- Close the choking elements (if provided)
- Switch on the master controller.
- Switch on the fan.



The fan may only be switched on when the pipes are connected and when it is certain that there will be a sufficient plant resistance after the fan motor has reached its full operating speed.

- Check the sense of rotation of the motor when the fan has started up for the first time (the motor must rotate in the direction indicated by the arrow).
- Check the power consumption. The maximum permissible power consumption may not be exceeded.
- Regularly check the bearings for unusual noises and check the temperature of the bearings in the first few operating hours.

5.2. Putting the fan out of operation

- Switch off the fan.
- Turn master controller to "OFF" and secure it against unauthorized use.

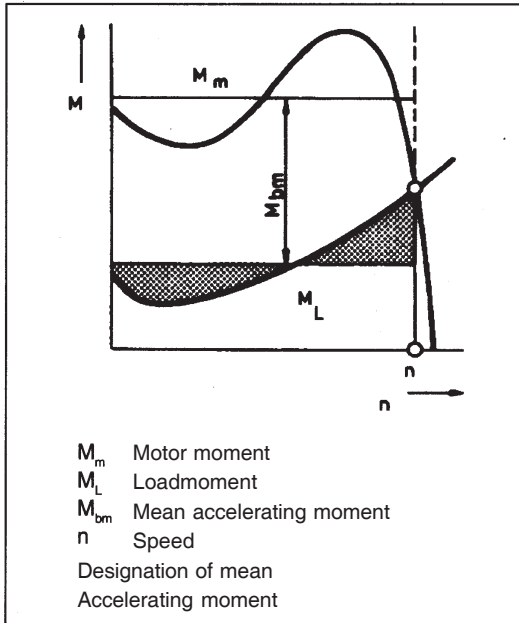

5.3. Transient behaviour

5.3.1 General



The fan can only be started when a sufficiently high moment of acceleration is available from the moment when the nominal speed is reached.

It is recommended to start the fan with the damper closed.



The customer has to check that his power network, switch gear, monitoring devices (if available) and cable cross sections are dimensioned to cope with the transient behaviour and current peaks.

5.3.2 Direct starting

Direct starting of the fan motor not only causes a high starting torque but also a high starting current.

During starting the starting current may be 6 to 8 times as high as the nominal current (depending on the type of rotor)

This high power input must be taken into account when the fuse sizes are determined.

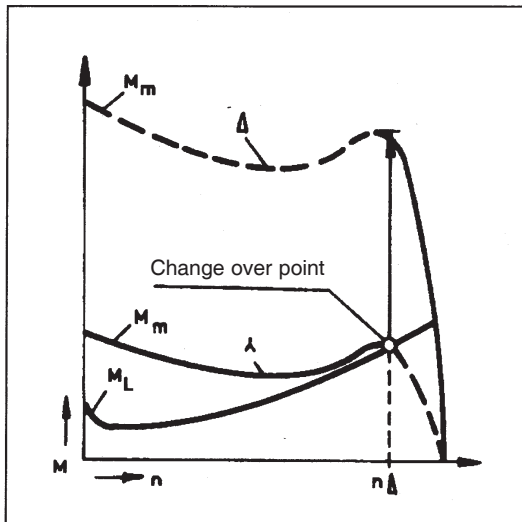

5.3.3 Star-delta starting

During star-delta starting the drive motor only provides for 1/3 of the starting torque in the star connection. At a certain starting speed the load moment of the fan exceeds the starting torque of the motor. The motor does not accelerate. At this point the motor has to be changed over to the delta connection. The current peak which is then obtained is clearly lower than the one occurring during direct starting.

6. CARE AND MAINTENANCE

6.1 Lubrication



The fan must be checked at regular intervals (depending on the operating conditions) for proper lubrication.

6.1.1 Drive motor

The motor must be serviced in accordance with the motor's lubricating instructions.

6.1.2 Shaft seal

The shaft seal is to be checked for leakages periodically. If the leakage are more, the sealing element has to be replaced.

6.1.3 Shaft bearings

The bearings have button-head lubricating nipples. Lubricate the bearings with a grease gun during operation.



Only use a lithium-saponified grease with a service temperature of -40/-20° C to +120/+150° C. Standard anti-friction bearings are filled with bearing grease as per lubrication chart furnished in this manual.

Replenish the bearings until the used grease is completely pressed out at the bottom of the bearing shell and fresh grease begins to flow out.



In the first few hours following lubrication the temperature inside the bearings rises. After the amount of excess grease has been driven out of the bearing housing the bearing temperature is reduced to the original level.

Lubricating intervals depend on the strain to which the grease is subjected (bearing friction, speed, bearing load and temperature).

6.1.4 OPERATING TECHNIQUE:

EACH SHIFT:

When taking over, operator must observe the following:

1. Fan bearings temperature is satisfactory-not in excess of 75 deg.C.
2. Vibrations of bearings are normal-not in excess of 6.6mm/sec RMS velocity.

ONCE PER WEEK:

1. When convenient to stop fan, operate dampers over entire range to prove satisfactory condition of moving parts.

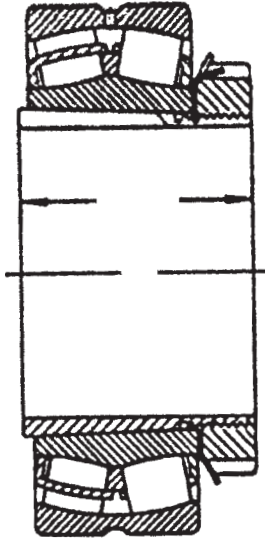

Double Spherical Roller Bearing with adapter sleeve.



Cylindrical Roller Bearing without adapter sleeve.

Changing of lubricating intervals through temperature	
Temp. bearing shell	Factor lubricating interval
75° C	x 1.00
80° C	x 0.85
85° C	x 0.70
90° C	x 0.55
95° C	x 0.45
100° C	x 0.35

Lubricating intervals and grease quantities are indicated in the lubricating table (for normal operating conditions).

The indicated lubricating intervals refer to a bearing temperature of 75°C. for other temperatures the intervals must be corrected in accordance with the table shown on the left.

Lubricating intervals

Housing	Antifriction bearing	Lubricating intervals (operating hours)			Grease quantity* (g)
		$n_L = 3000 \text{ min}^{-1}$	$n_L = 1500 \text{ min}^{-1}$	$n_L = 1000 \text{ min}^{-1}$	
Type with clamping sleeve - tapered bearing					
607/080	2307K	4000	4000	4000	65
608/090	2308K	3600	4000	4000	85
609/100	2309K	3200	4000	4000	115
610/110	2310K	2950	4000	4000	150
611/120	2311K	2700	4000	4000	185
612/130	2312K	2500	4000	4000	220
613/140	2313K	2250	4000	4000	270
615/160	2315K	2000	3800	4000	370
616/170	2316K	1900	3600	4000	460
617/180	2317K	1800	3400	4000	550
618/190	2318K	1700	3300	4000	650
619/200	2319K	1600	3100	4000	750
515/130	22215K	-	800	1350	350
516/140	22216K	-	750	1250	460
517.150	22217K	-	700	1200	550
518/160	22218K	-	650	1100	650
519/170	22219K	-	580	1000	750
520/180	22220K	-	540	950	850
522/200	22222K	-	460	850	1100
524/215	22224K	-	410	750	1150
Type without clamping sleeve - cylindrical bearing					
315/160	2315	2000	3800	4000	650
316/170	2316	1900	3600	4000	750
317/180	2317	1800	3400	4000	850
318/190	2318	1700	3300	4000	975
319/200	2319	1600	3100	4000	1100
218/160	22218	-	650	1100	650
220/180	22220	-	540	1100	850
222/200	22222	-	460	850	1100
224/215	22224	-	410	750	1450
226/230	22226	-	360	680	1850
228/250	22228	-	300	600	2300
230/270	22230	-	260	520	2800
232/290	22232	-	220	460	3500

* Quantity per bearing (corresponding to approx. 60% of the bearing housing volume).



To ensure that the fresh grease reaches all points of the bearing it is necessary to replenish the amount indicated in table.



OIL LUBRICATION

In case of oil lubrication of Fan bearings, the following lubricants are recommended.

Bearing	Brg.Hsg. No.	Initial Fill Ltrs	Initial Fill (mm)	
			Max	Min
22216 CC/C3	216	1.0	60	48
22218 CC/C3	218	1.1	60	48
22220 CC/C3	220	1.2	65	50
22222 CC/C3	222	1.3	77	50
22322 CC/C3	322	2.0	95	67
22224 CC/C3	224	1.7	80	60
22324 CC/C3	324	2.8	100	65
22226 CC/C3	226	2.3	85	60
22326 CC/C3	326	3.4	105	70
22228 CC/C3	228	2.4	85	60
22328 CC/C3	328	4.2	115	70
22230 CC/C3	230	2.8	90	60
22330 CC/C3	330	6.0	120	75
22232 CC/C3	232	3.3	95	65
22332 CC/C3	332	6.5	125	80
22234 CC/C3	234	5.0	105	75
22334 CC/C3	334	7.5	130	85
22236 CC/C3	236	5.2	115	80
22336 CC/C3	336	10.5	155	90
22238 CC/C3	238	5.8	120	85
22240 CC/C3	240	7.0	125	85
22244 CC/C3	244	8.5	140	95
22248 CC/C3	248	9.5	155	110

- Oil with viscosity grade of 46 (or) 68 (or) 100, as applicable.
- Make : IOCL, BPCL, HPCL.



LUBRICATION:

GREASE LUBRICATION:

Following lubricants for fan bearings are recommended, if the speed of fans is below 1500 RPM and temperature of air\gas handled by fan is not more than 200 deg.C

Servogem 2 of IOCL
 Servogem 3 of IOCL
 Supertec PDOO of Balmer Lawrie
 Or Equivalent

If the speed of fan is more than 1500 RPM but less than 3500 RPM and or temperature of air\gas handled by fan is more than 200 deg.C., then following lubricants are recommended.

Servogem EP.2/Servogem EP3 of IOCL
 Lithoplex EP2 of IPCL
 Supertec PD2 of Balmer Lawrie or equivalent.

GREASING TO STANDARD SN 500 SERIES BEARING HOUSINGS

Bearing No.	Bearing Housing No.	Initial fill (gms\brg)	Greasing Interval (hrs)	Refilling Quantity (gms\brg)	Replacement Interval of grease (hrs)
22209 EK	SN 509	80	1600	10	10,000
22211 EK	SN 511	130	1600	20	10,000
22213 EK	SN 513	200	1600	25	10,000
22215 EK	SN 515	300	1600	40	10,000
22216 EK	SN 516	350	1600	50	10,000
22217 EK	SN 517	400	1200	50	10,000
22218 EK	SN 518	500	1200	70	8,000
22220 EK	SN 518	700	1200	100	8,000
22222 EK	SN 520	900	800	120	6,000
22224 EK	SN 524	1100	800	150	6,000
22226 EK	SN 526	1400	800	200	6,000
22228 CCK	SN 528	1400	800	200	6,000
22232 CCK	SN 532	2000	800	250	6,000
23134 CCK	SD 3134	1800	800	250	4,000
23136 CCK	SD 3136	2200	800	300	4,000
23138 CCK	SD 3138	2900	800	400	4,000

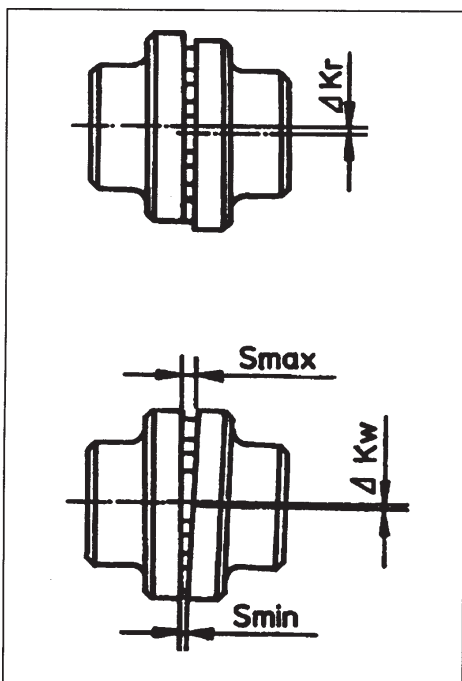

6.2 Coupling

6.2.1 Service

In resilient coupling, greasing has to be done periodically.

6.2.2 Alignment

when aligning the coupling care must be taken that the angular offset and radial offset of the shaft ends are kept as small as possible.

Permissible offset → table “guide values for permissible shaft offsets and gap widths”.

Align the coupling in two axial planes which are normal to each other.

Check the radial offset (ΔK_r) with a ruler and the angular offset (ΔK_w) with a thickness gauge (feeler gauge).

 The accuracy of alignment can be improved by using a dial gauge or a laser-type optical sensor.

Speed in RPM	Guide values for permissible shaft radial offsets and angular offsets		
3000	Radial offset	Δk_r (mm)	0.03
	Angular offset	Δk_w (mm)	0.05
1500	Radial offset	Δk_r (mm)	0.05
	Angular offset	Δk_w (mm)	0.05
1000	Radial offset	Δk_r (mm)	0.05
	Angular offset	Δk_w (mm)	0.05

For Gap between two couplings halves, refer to G.A. drawing fan.

6.3 Troubleshooting

Malfunction	Possible cause	Action	
Unsteady operation of fan.	Material sticking to impeller blades	Carefully clean impeller.	
	Worn impeller.	Replace impeller.	
	Impeller deformed by heat.	Replace Impeller.	
	Strain exerted by connected ducts pipes.	Remove fan from foundation and level foundation again. Correct setting.	
Medium escapes at the shaft seal.	Seal is faulty or worn out.	Use flexible pipe connections (compensators).	
Fan produces a grinding noise.	Impeller rubs against nozzle.	Loosen housing cover and inlet re-align, check and correct pipe if necessary.	
	Motor noise.	Check if bearings are damaged and replace bearings if necessary.	
	Too much air.	Reduce air volume using a choking element until the permissible power input is reached.	
The power input indicated on the rating plate is constantly exceeded.	Different speed with 60 Hz mains.	Check frequency.	
	Fan does not accelerate.	Improper connection of drive motor.	Check connection.
		Motor does not change from star to delta connection.	Shorten change-over time from star to delta.
	Fan operates against insufficient plant resistance.	Close choking elements or install additional plate shutters.	
	Motor protection system is not strong enough.	Cable cross section and protective system must withstand starting current during acceleration.	

6.3 1 Troubleshooting Shaft defects

Malfunction	Possible cause	Action
Unsteady operation.	Starting time is too long.	Close choking elements, check starting torque of M_A/M_N motor.
	Faulty drive motor.	Check motor and replace if necessary.
	Starting/re-starting when fan is hot.	Switching frequency too high, let motor run through (control via choking element).
	Starting current too high.	Wrong voltage. Provide star-delta starting, local mains not strong enough.
	Damaged races and rolling elements.	Replace bearing.
Unusual running noises: Whinnying or whistling noise.	Excessive bearing clearance.	Protect bearing against dirt.
	Wear caused by dirt or insufficient lubrication.	Use clean grease.
	Insufficient internal clearance.	Use bearing with sufficient internal clearance.
Running noise is changing gradually.	Excessive internal clearance, damaged rolling surfaces, dirt.	Replace bearing.
	Wrong lubricant.	Use correct lubricant.
	Change of internal clearance caused by temperature changes, damaged raceway (e.g. by dirt or fatigue).	Protect bearing against heat/cold.



6.3.2 Troubleshooting Coupling defects

Malfunction	Possible cause	Action
Unsteady operation. Powerful shocks on attempt.	Coupling flanges don't stay optimal.	Alignment looking over.
	Flexible elements are nagged.	Change Flexible elements.
	Flexible elements too soft.	Flexible elements with higher shore-hardness to be used.
	Flexible elements are nagged.	Flexible elements to be changed.
	Starting power of motors too high.	Star-delta-wiring to be used.

6.4 Queries/Spare Parts order

If you have any queries or want to order for spare parts, please ensure furnishing the following details, to Reitz India Limited.

- Model no. of the fan (Number indicated on the name plate of the fan)
- Reitz Job Order No.
- Purchase Order No. and date of supply
- An exact description will allow us to respond more quickly and efficiently. Information sent out by FAX will be very much appreciated.

Reitz India is committed to provide quality after sales service at economical price by our experienced service engineers. Please contact Reitz India Ltd., for their per-diem rates for supervision of erection, commissioning and repairs.

Please Contact:

REITZ INDIA LIMITED

'Serene Towers', 8-2-623/A, Road No.10,
Banjara Hills, Hyderabad - 500 034. India

Tel: +40-23301888 (6 lines) **Fax:** +40-2330 8521

E-mail: info@reitzindia.com

Websites: www.reitzindia.com www.reitz-ventilatoren.de

- Bangalore: +99002 12572 ● Chennai: +93810 63065 ● Kolkata: +93310 07535
- Mumbai: +93222 95348 ● New Delhi: +98733 12255 ● Raipur: +98935 52030